



Certificate of Accreditation

Sewage Management Facility

Septic Tanks & Collection Wells

This Certificate of Accreditation is issued by the Secretary of the NSW Ministry of Health pursuant to Clause 41(1) of the Local Government (General) Regulation 2005.

Manufacturer: *Highland Tanks Pty Ltd*
TA: *Highland Concrete Tanks*

Of: *16 Gantry Place, Braemar, NSW, 2575*

The Highland Concrete Septic Tanks and Collection Wells as described in the following Schedule have been accredited as a sewage management facility for use in single domestic premises in NSW.

*A/Director, Environmental Health
for Secretary (delegation PH335)*

Issued: *20 / 10 / 2021*

Certificate No: *STCW005*

Expires: *31 December 2025*



Accreditation Schedule

*The Certificate of Accreditation applies to the following
Septic Tanks and Collection Wells*

| Model | Description | Size |
|--|--|---|
| Septic Tank | Vertical axis cylindrical precast steel fibre reinforced concrete, with partition, lid, access cover. Tank lid burial depth is restricted to 0 mm | 4500 L 7100 L |
| Collection Well | Vertical axis cylindrical precast steel fibre reinforced concrete tank, with lid and access covers. Certification applies only to the construction of the tank, lid and access covers. It does not include the internal fittings or partitions. Tank lid burial depth is restricted to 0 mm | 4000L 6000L 6200 L 7300 L 8500 L 10000 L |
| Combined Septic Tank and Collection Well (7800 L) | Vertical axis cylindrical precast steel fibre reinforced concrete tank, with lid and access covers. Certification applies only to the construction of the tank, lid and access covers. It does not include the internal fittings or partitions. Tank lid burial depth is restricted to 0 mm | 2550 L ST 5000 L CW 3000 L ST 4550 L CW |

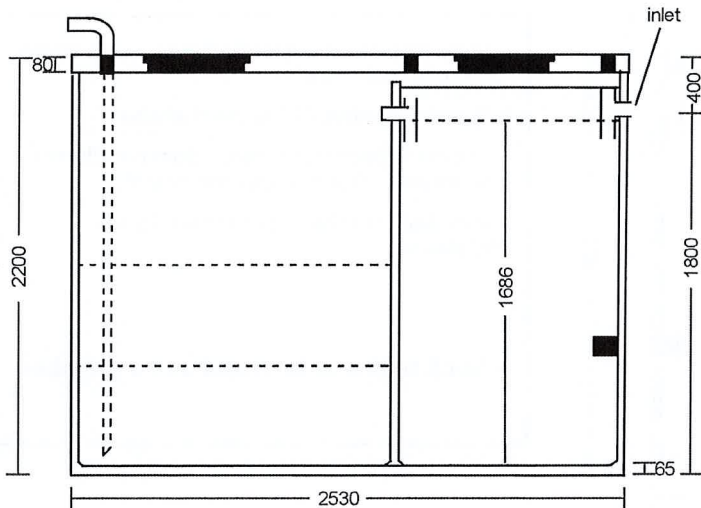

- Inspection holes are located over inlet & outlet of septic chambers
 - Manhole centres 600mm in diameter
 - Cut out in secondary baffle 100mm x 150mm and located 700mm from base of tank
 - Support pipes 50mm DWV, fixed in collection well
 - Main baffle sealed in place with 2 part megapoxy
 - Lifting pins at base of tank
- Suction line to be installed by plumber**

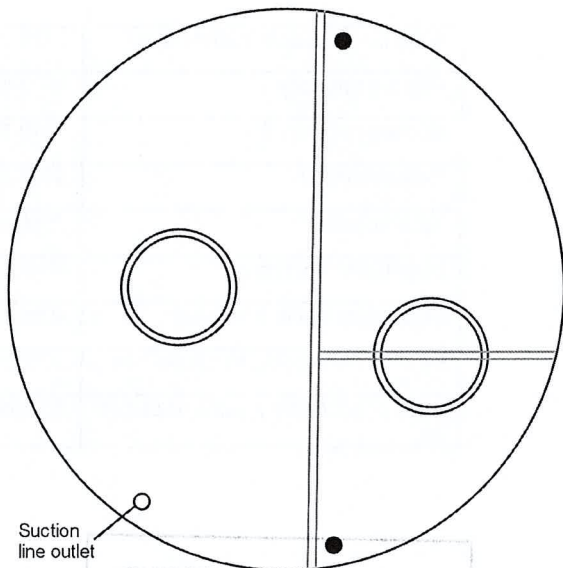

| | |
|---|------------|
| Total tank capacity outlet septic | 7774 litre |
| Primary capacity 1 | 2000 litre |
| Primary capacity 2 | 1000 litre |
| Collection well | 4551 litre |
| Total volume | 7551 litre |
| Main baffle thickness | 55mm |
| Secondary baffle thickness | 40mm |
| Face of main baffle to centre line | 163mm |
| Face of secondary baffle to centre line | 241mm |

ACCREDITED

20 OCT 2021

NSW MINISTRY OF HEALTH

7774 litre
COMBINED SEPTIC TANK & COLLECTION WELL
 No. HCT1 – 3000 litre primary

COLLECTION WELLS
 manufactured by
 Highland Tanks Pty Ltd ACN 090 907 725 trading as
Highland Concrete Tanks
 Postal: PO Box 1158, MITTAGONG NSW 2575
 Factory: 16 Gantry Place, BRAEMAR NSW 2575
 Phone: 02 4871 2156 Fax: 02 4872 4109

Collection Wells
 manufactured to comply
 with Australian Standards

AS/NZS 1546.1:2008

Highland Concrete Tanks

Designed by: DW Rebbeck

Drawing No.
HCT1
 20/02/2021

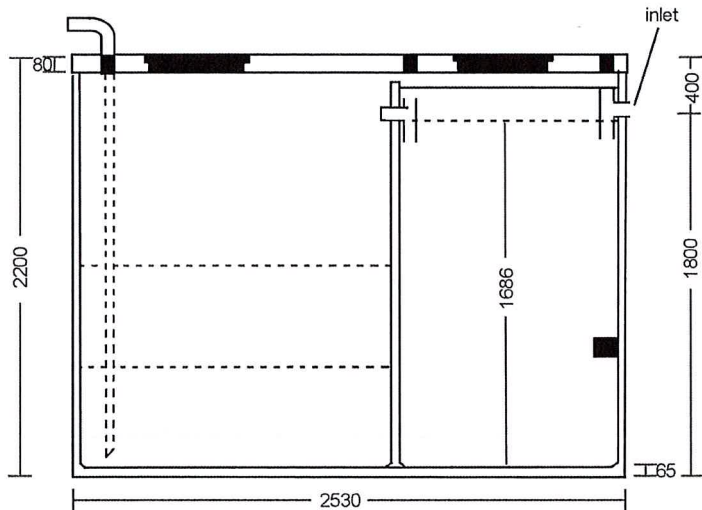

- Inspection holes are located over inlet & outlet of septic chambers
- Manhole centres 600mm in diameter
- Cut out in secondary baffle 100mm x 150mm and located 700mm from base of tank
- Main baffle sealed in place with 2 part megapoxy

- Suction line to be installed by plumber

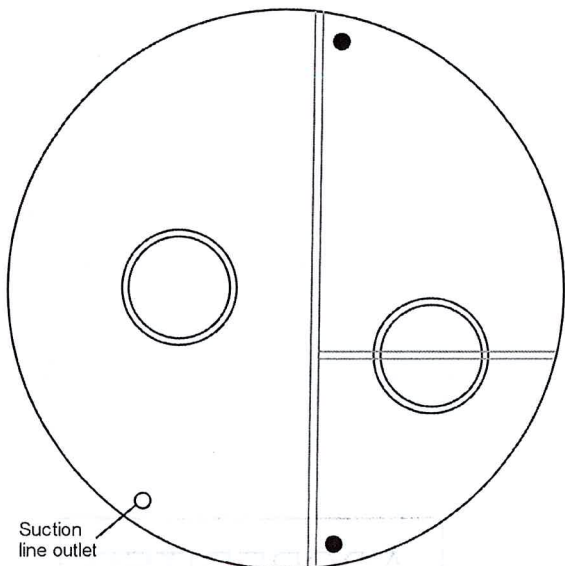

| | |
|---|------------|
| Total tank capacity outlet septic | 7774 litre |
| Primary capacity 1 | 1635 litre |
| Primary capacity 2 | 818 litre |
| Collection well | 5105 litre |
| Total volume | 7558 litre |
| Main baffle thickness | 55mm |
| Secondary baffle thickness | 40mm |
| Face of main baffle to centre line | 301mm |
| Face of secondary baffle to centre line | 207mm |

ACCREDITED

20 OCT 2021

NSW MINISTRY OF HEALTH

7774 litre

COMBINED SEPTIC TANK & COLLECTION WELL

No. HCT2 – 2453 litre primary

COLLECTION WELLS

manufactured by

Highland Tanks Pty Ltd ACN 090 907 725 trading as
Highland Concrete Tanks

Postal: PO Box 1158, MITTAGONG NSW 2575

Factory: 16 Gantry Place, BRAEMAR NSW 2575

Phone: 02 4871 2156 Fax: 02 4872 4109

Collection Wells
manufactured to comply
with Australian Standards

AS/NZS 1546.1:2008

Highland Concrete Tanks

Designed by: DW Rebeck

Drawing No.

HCT2

20/02/2021

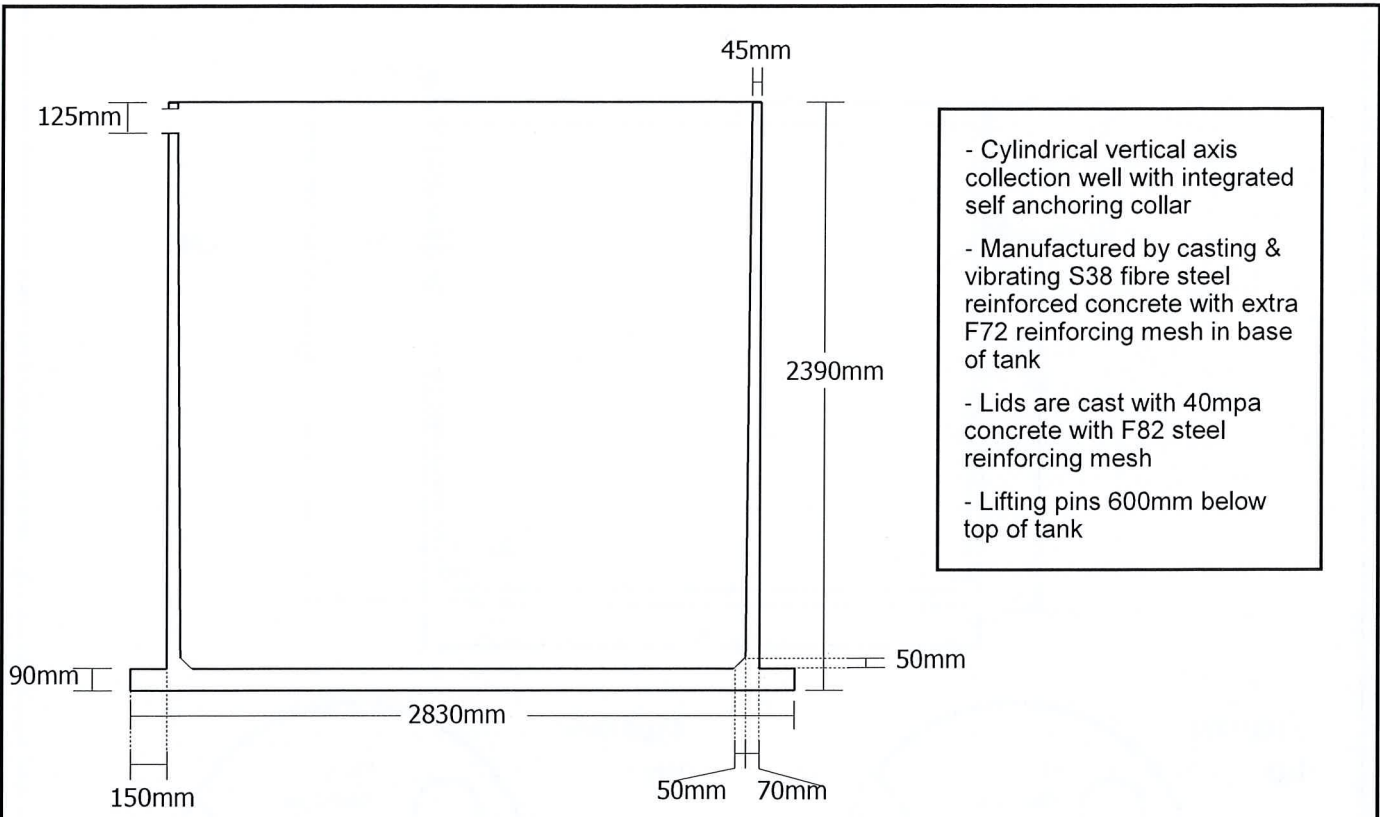

- Cylindrical vertical axis collection well with integrated self anchoring collar
- Manufactured by casting & vibrating S38 fibre steel reinforced concrete with extra F72 reinforcing mesh in base of tank
- Lids are cast with 40mpa concrete with F82 steel reinforcing mesh
- Lifting pins 600mm below top of tank

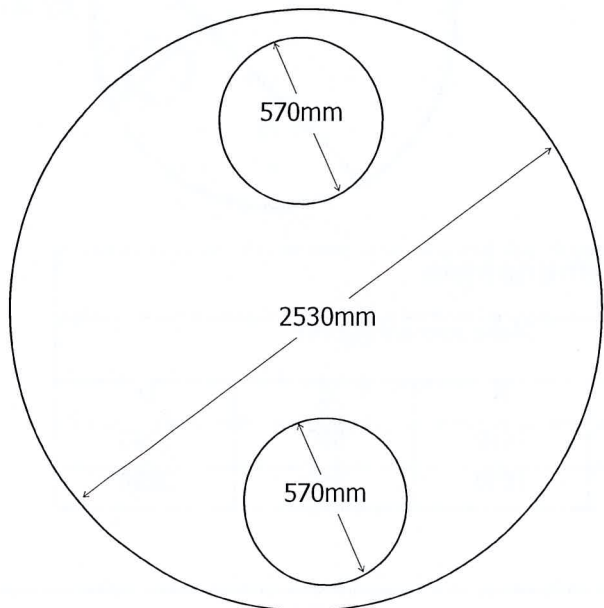

ACCREDITED
20 OCT 2021
NSW MINISTRY OF HEALTH

80mm thick lid | 1 x F82 steel reinforcing mesh

**10,000 litre
COLLECTION WELL**

| | | |
|--|---|---|
| <p>COLLECTION WELLS manufactured by Highland Tanks Pty Ltd ACN 090 907 725 trading as Highland Concrete Tanks Postal: PO Box 1158, MITTAGONG NSW 2575 Factory: 16 Gantry Place, BRAEMAR NSW 2575 Phone: 02 4871 2156 Fax: 02 4872 4109</p> | <p>Collection Wells manufactured to comply with Australian Standards</p> <p>AS/NZS 1546.1:2008</p> <p>Highland Concrete Tanks</p> <p>Designed by: DW Rebbeck</p> | <p>Drawing No.</p> <p style="font-size: 2em; font-weight: bold; text-align: center;">HCT3</p> <p>20/02/2021</p> |
|--|---|---|

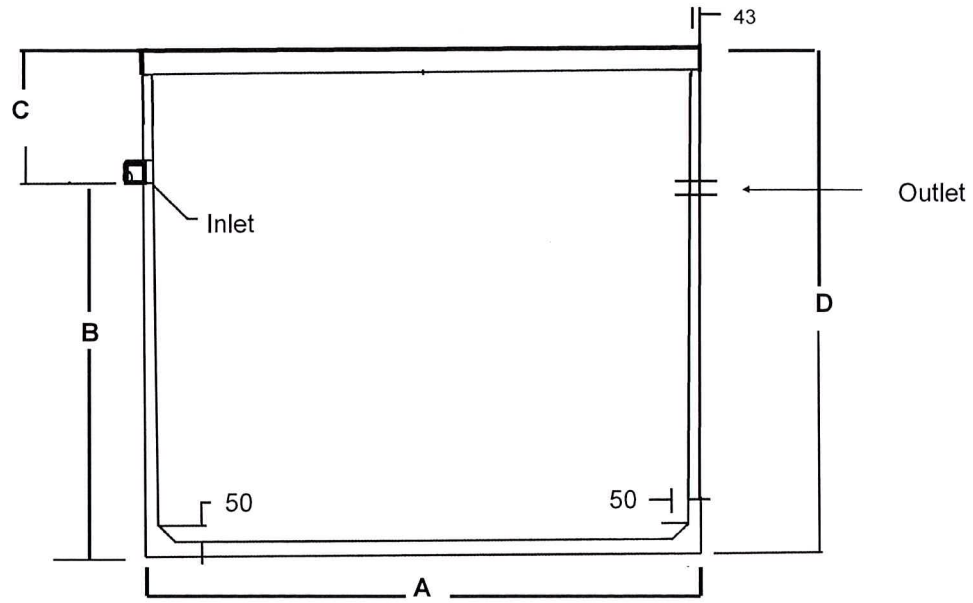

**7100 litre
LID**

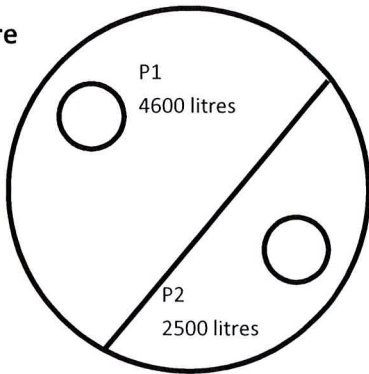

**4500 litre
LID**

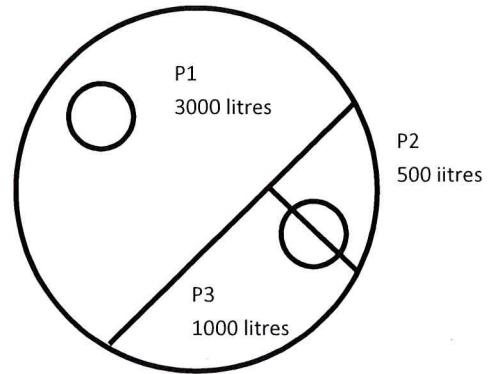

Septic Tank Dimensions

| Volume (Litres) | Type | Measurements (mm) | | | |
|-----------------|-------------|-------------------|------|-----|------|
| | | A | B | C | D |
| 4500 | Septic Tank | 2200 | 1450 | 550 | 2000 |
| 7100 | Septic Tank | 2530 | 1650 | 550 | 2200 |

ACCREDITED

20 OCT 2021

NSW MINISTRY OF HEALTH

4500 litre

7100 litre

SEPTIC TANKS

**COLLECTION WELLS & SEPTIC TANKS
manufactured by**

Highland Tanks Pty Ltd ACN 090 907 725 trading as
Highland Concrete Tanks

Postal: PO Box 1158, MITTAGONG NSW 2575

Factory: 16 Gantry Place, BRAEMAR NSW 2575

Phone: 02 4871 2156 Fax: 02 4872 4109

Collection Wells &
Septic Tanks
manufactured to comply
with Australian Standards

AS/NZS 1546.1:2008

Highland Concrete Tanks

Designed by: DW Rebbeck

Drawing No.

HCT4

20/02/2021

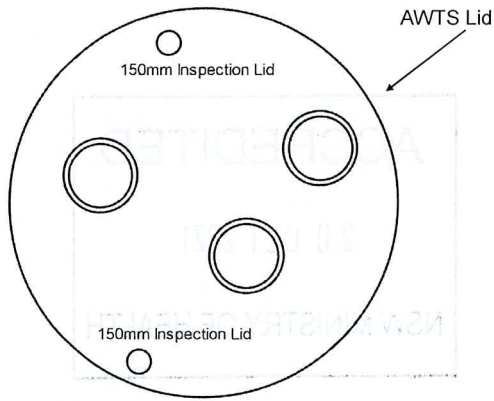

ACCREDITED

20 OCT 2021

NSW MINISTRY OF HEALTH

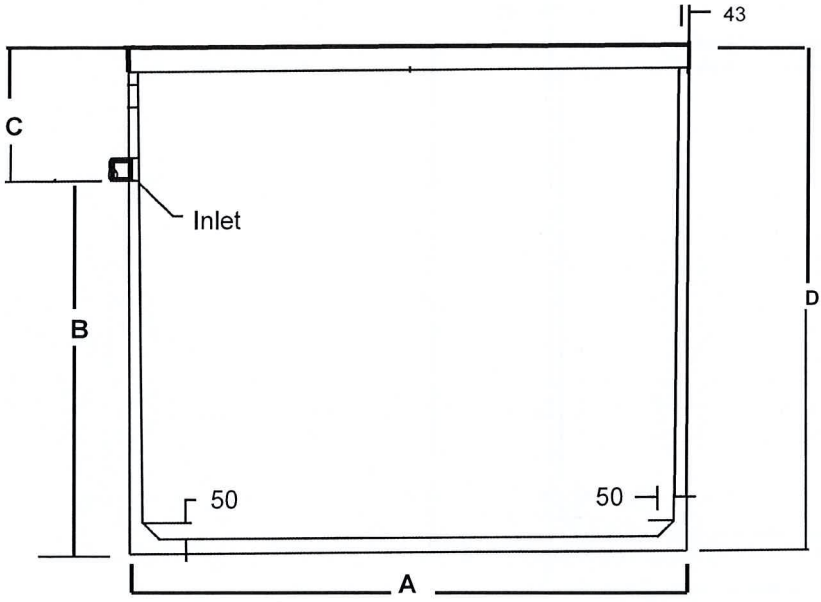

| Collection Well Dimensions | | | | | |
|----------------------------|-----------------|-------------------|------|-----|------|
| Volume (Litres) | Type | Measurements (mm) | | | |
| | | A | B | C | D |
| 6200 | Collection Well | 2500 | 1450 | 750 | 2200 |
| 7300 | Collection Well | 2500 | 1650 | 550 | 2200 |
| 8500 | Collection Well | 2500 | 1950 | 250 | 2200 |

6200/7300/8500 litre

AWTS

COLLECTION WELLS

COLLECTION WELLS
manufactured by
 Highland Tanks Pty Ltd ACN 090 907 725 trading as
Highland Concrete Tanks
 Postal: PO Box 1158, MITTAGONG NSW 2575
 Factory: 16 Gantry Place, BRAEMAR NSW 2575
 Phone: 02 4871 2156 Fax: 02 4872 4109

Collection Wells &
 Septic Tanks
 manufactured to comply
 with Australian Standards
AS/NZS 1546.1:2008

Highland Concrete Tanks
 Designed by: DW Rebbeck

Drawing No.
UC1
 20/02/2021

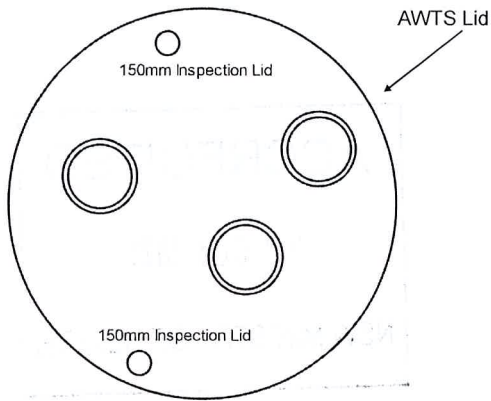

ACCREDITED

20 OCT 2021

NSW MINISTRY OF HEALTH

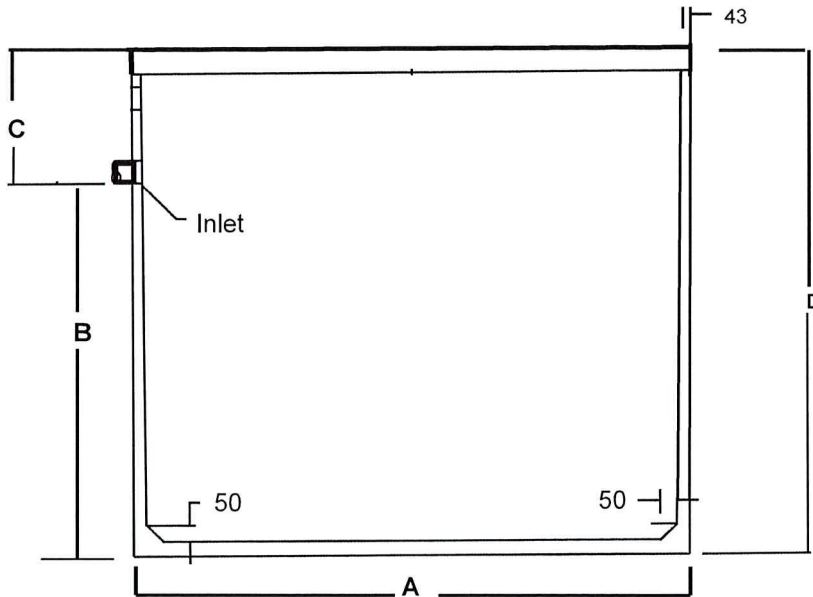

Collection Well Dimensions

| Volume (Litres) | Type | Measurements (mm) | | | |
|-----------------|-----------------|-------------------|------|-----|------|
| | | A | B | C | D |
| 6200 | Collection Well | 2500 | 1450 | 850 | 2300 |
| 7300 | Collection Well | 2500 | 1650 | 650 | 2300 |
| 8500 | Collection Well | 2500 | 1950 | 350 | 2300 |

**6200/7300/8500 litre
AWTS extended height
COLLECTION WELLS**

COLLECTION WELLS

manufactured by

Highland Tanks Pty Ltd ACN 090 907 725 trading as
Highland Concrete Tanks

Postal: PO Box 1158, MITTAGONG NSW 2575

Factory: 16 Gantry Place, BRAEMAR NSW 2575

Phone: 02 4871 2156 Fax: 02 4872 4109

Collection Wells &
Septic Tanks
manufactured to comply
with Australian Standards

AS/NZS 1546.1:2008

Highland Concrete Tanks

Designed by: DW Rebbeck

Drawing No.

UC2

20/02/2021

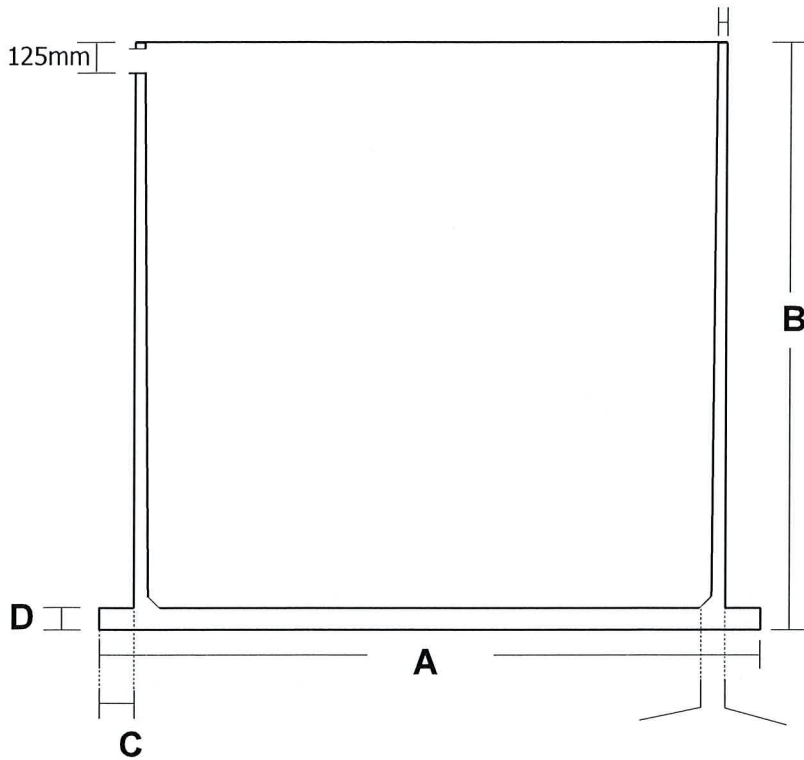

- Cylindrical vertical axis collection well with integrated self anchoring collar

- Manufactured by casting & vibrating S38 fibre steel reinforced concrete with extra F72 reinforcing mesh in base of tank

- Lids are cast with 40mpa concrete with F82 steel reinforcing mesh

- Lifting pins 600mm below top of tank

ACCREDITED

20 OCT 2021

NSW MINISTRY OF HEALTH

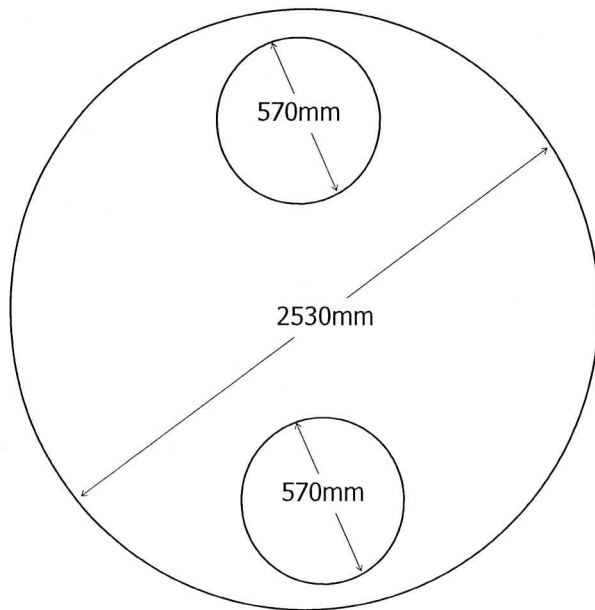

| VOLUME litres | A WIDTH mm | B HEIGHT mm | C I.S.A.C. WIDTH mm | D BASE mm |
|---------------|------------|-------------|---------------------|-----------|
| 6,000 | 2830 | 1500 | 150 | 90 |
| 4,000 | 2730 | 1070 | 100 | 70 |

80mm thick lid | 1 x F82 steel reinforcing mesh

**6,000 litre & 4,000 litre
COLLECTION WELL**

COLLECTION WELLS

manufactured by

Highland Tanks Pty Ltd ACN 090 907 725 trading as
Highland Concrete Tanks

Postal: PO Box 1158, MITTAGONG NSW 2575

Factory: 16 Gantry Place, BRAEMAR NSW 2575

Phone: 02 4871 2156 Fax: 02 4872 4109

Collection Wells
manufactured to comply
with Australian Standards

AS/NZS 1546.1:2008

Highland Concrete Tanks

Designed by: DW Rebbeck

Drawing No.

HCT5

15/06/2021