



Health

Certificate of Accreditation

Sewage Management Facility

Septic Tanks & Collection Wells

This Certificate of Accreditation is issued by the Secretary of the NSW Ministry of Health pursuant to Clause 41(1) of the Local Government (General) Regulation 2005.

Manufacturer: *Precast Civil Industries Pty Ltd
t/a Icon Septech VIC*

Of: *11-13 Industrial Drive, Pakenham, VIC, 3810*

The Icon Septic VIC range of concrete Septic Tanks, Collection Wells and Pump Wells as described in the following Schedule have been accredited as sewage management facilities for use in single domestic premises in NSW.

*Director, Environmental Health
for Secretary (delegation PH335)*

Issued: *8 January 2019*
Certificate No: *STCW024*
Expires: *31 December 2024*



Health

Accreditation Schedule

*The Certificate of Accreditation applies to the following
Septic Tanks, Collection Wells and Pump Wells*

Model	Description	Size
Septic Tank	Horizontal axis cylindrical precast concrete with steel reinforcing mesh or steel fibre reinforcement with partition, access cover, inlet/outlet fittings. Burial depth of the tank lid is restricted to 2 mm	3200 L 4250 L
Collection Well	Horizontal axis cylindrical precast concrete with steel reinforcing mesh or steel fibre reinforcement. Certification applies only to the construction of the tank and access cover. It does not include the internal fittings or partitions. Burial depth of the tank lid is restricted to 2 mm	3200 L
Collection Well/ Pump Well	Vertical axis cylindrical precast concrete with steel reinforcing mesh or steel fibre reinforcement with access cover. Certification applies only to the construction of the tank and access cover. It does not include the internal fittings or partitions. Burial depth of the tank lid is restricted to 0 mm	950 L 1050 L 1700 L 2050 L 3750 L 3800 L 4650 L 10,500 L

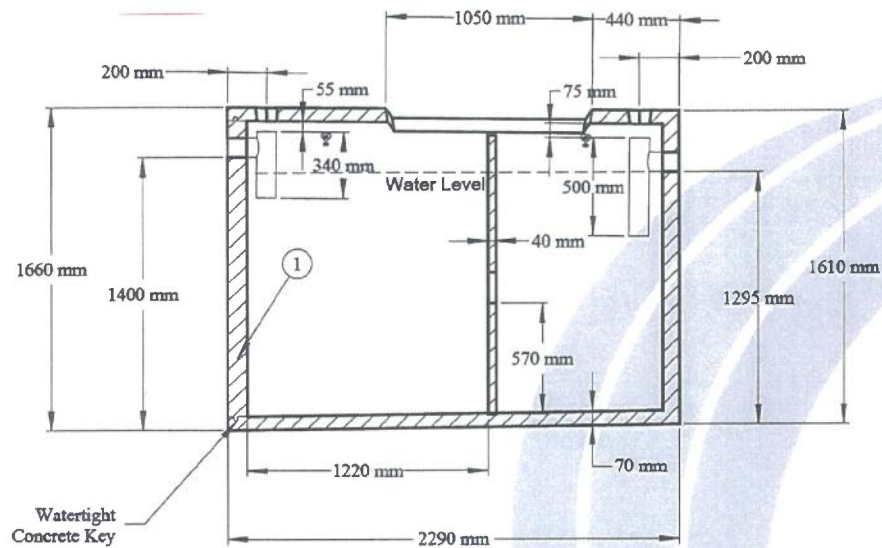

SECTION A-A

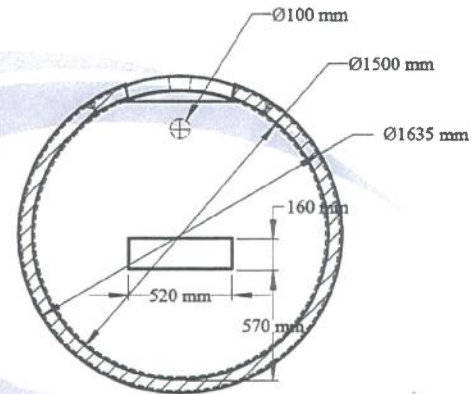

SECTION B-B

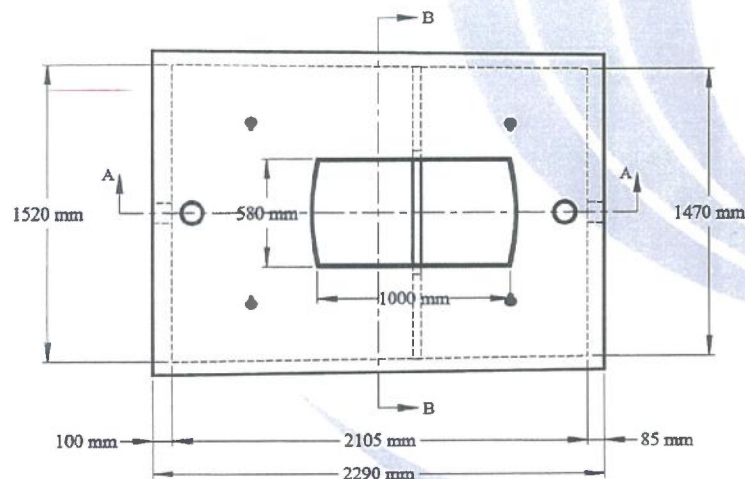

PLAN VIEW

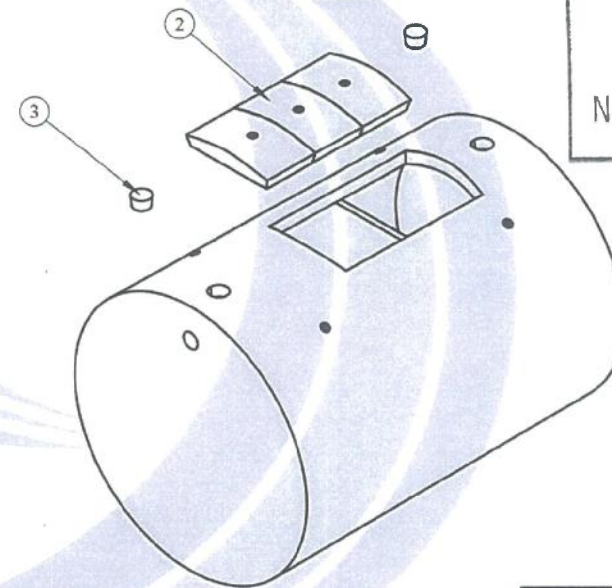

ISOMETRIC VIEW

LIFTING

4 FA x 1.3t x 55mm

TOTAL MASS

2.819 tonne

NOTES

Excavation Details:

Length - 2500mm
Width - 1900mm
Depth - 1800mm

APPROVED

- 8 JAN 2019

NSW MINISTRY OF HEALTH



ICON SEPTTECH
VIC

W: www.mcpipes.com.au

T: 1300 557 143

TITLE

3,200 Litre Septic Tank, for Turbojet 2000 System

NO	ITEM CODE	QTY	DESCRIPTION
1	600V001B	1	3,200L Septic Tank
2	600V007	1	3 Part Curved Septic Tank Lid
3	VFT50028	2	Septic Bungs

UNCONTROLLED ONCE PRINTED		
NO	DATE	REVISIONS
0	04/02/2010	Product Redrawn

SCALE	1:25	DWG NO	REV
DATE	04/02/2010	602V003	0
DRAWN	R. Hourani	CHECKED	G. Rodriguez

SIZE A3

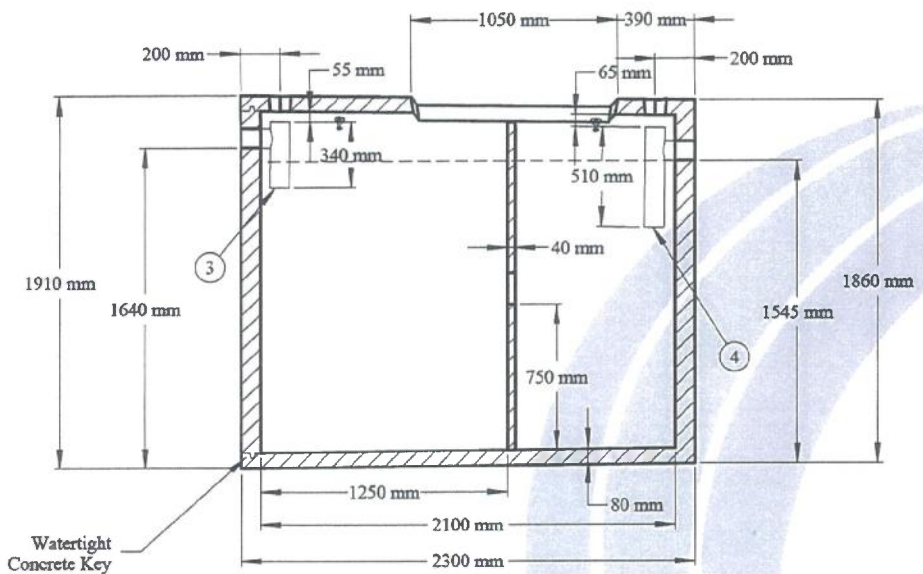

SECTION A-A

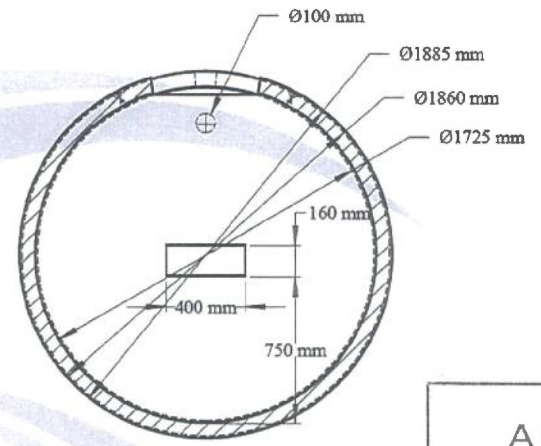

SECTION B-B

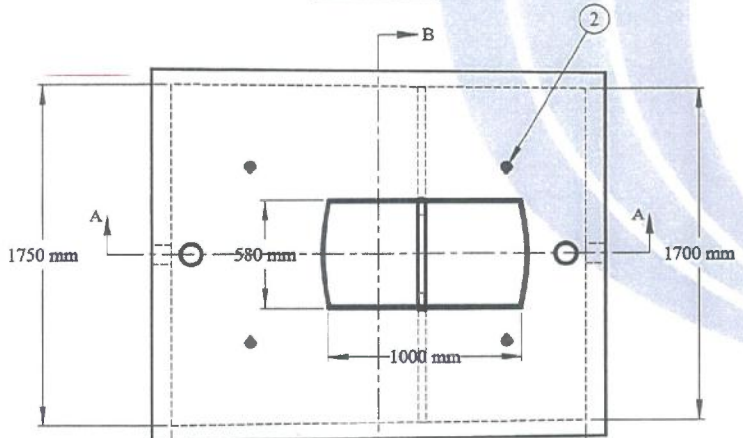

PLAN VIEW

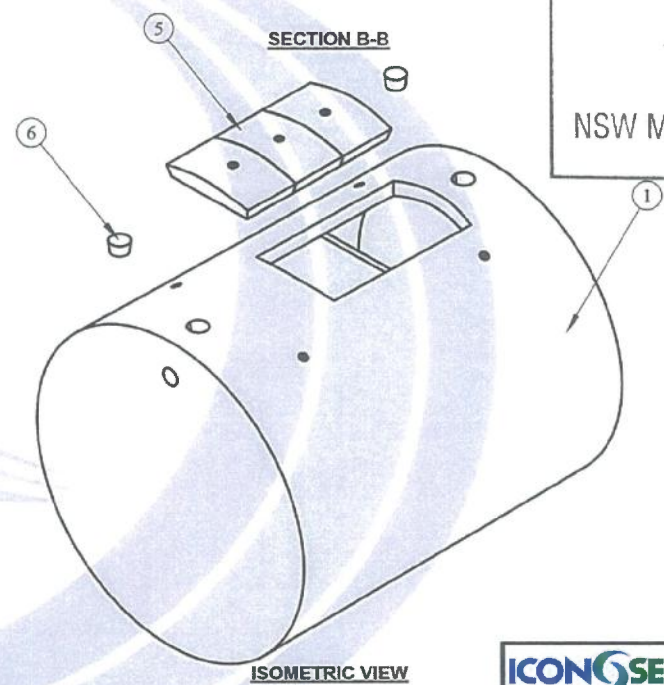

ISOMETRIC VIEW

LIFTING
4 FA x 1.3t x 55mm

TOTAL MASS
4.267 tonne

NOTES
Excavation Details:
Length - 2500mm
Width - 2250mm
Depth - 2100mm

APPROVED
 - 8 JAN 2019
 NSW MINISTRY OF HEALTH



NO	ITEM CODE	QTY	DESCRIPTION
1	600V022	1	4,500L Septic Tank
2	VAN13055	4	Foot Anchor - 1.3t x 55mm
3	605A036	1	Inlet T - 100mm x 340mm
4	605A037	1	Outlet T - 100mm x 510mm
5	600V007	1	3 Part Curved Septic Tank Lid
6	VFT50028	2	Septic Bungs

UNCONTROLLED ONCE PRINTED	
NO	DATE
0	15/02/2010
Product Redrawn	
REVISIONS	

ICON SEPTTECH VIC	
W: www.mcpipes.com.au T: 1300 557 143	
TITLE	
4,500 Litre Septic Tank	
SCALE	1:25
DATE	15/02/2010
DWG NO	600V022
REV	0
DRAWN	R. Hourani
CHECKED	D. Egan
SIZE	A3

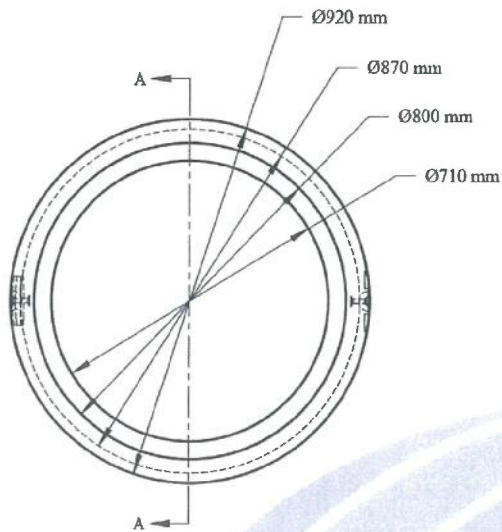

PLAN VIEW

ISOMETRIC VIEW

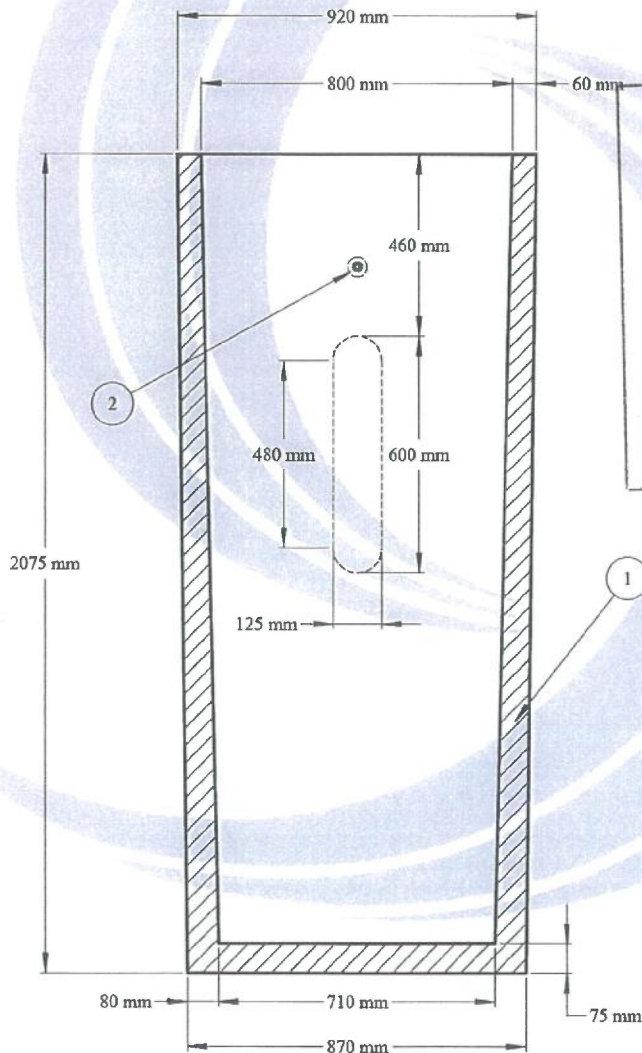

SECTION A-A

APPROVED
 - 8 JAN 2019
 NSW MINISTRY OF HEALTH

LIFTING

2 FA x 1.3t x 45mm

TOTAL MASS

1.016 tonne

NOTES

SAME DIMENSIONS AS 1050L PUMPWELL



ICON SEPTTECH
VIC

W: www.mcpipes.com.au

T: 1300 557 143

TITLE

950 Litre Pump Well

UNCONTROLLED ONCE PRINTED

NO	ITEM CODE	QTY	DESCRIPTION	NO	DATE	REVISIONS	SCALE	DATE	DWG NO	REV	SIZE
1	600V008	1	950L Pump Well				1:12.5	10/02/2010	600V008	0	A3
2	VAN13045	2	Foot Anchor - 1.3t x 45mm	0	10/02/2010	Product Redrawn					
3											

DRAWN	R. Hourani	CHECKED	D. Egan
-------	------------	---------	---------

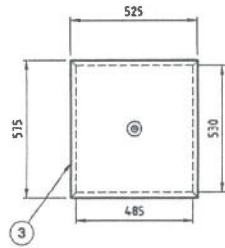

LID PLAN VIEW

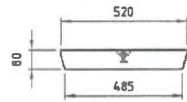

LID FRONT VIEW

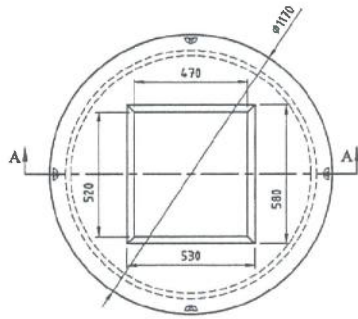

PLAN VIEW

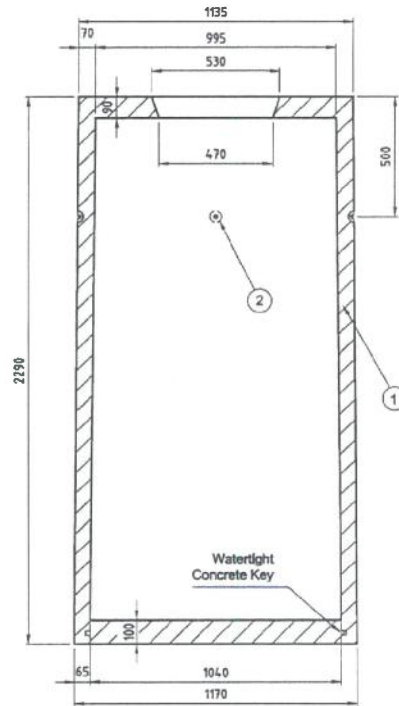

SECTION A-A

APPROVED
 - 8 JAN 2019
 NSW MINISTRY OF HEALTH

CLASS RATING
STANDARD DUTY

LIVE LOAD LIMITS
Maximum 0.5t GVM

DEAD LOAD
0 to 2.0m of Fill

CONCRETE GRADE
40MPa

LIFTING
4 x 1.3t Swivel Anchors (1FA055)

TOTAL MASS
1.575 tonne

NOTES
Reinforcement, refer to Bill of Materials



TITLE
**1,700 Litre Concrete Tank
Standard Duty**

NO	ITEM CODE	QTY	DESCRIPTION
1	565V1700SD	1	1,700L Concrete Tank
2	1FA055	4	Foot Anchor - 1.3t x 55mm
3	600V006	1	Square Manhole Cover 575 x 525

NOT FOR DISTRIBUTION		
UNCONTROLLED ONCE PRINTED		
0	Product Redrawn	02.06.14
REV	REVISIONS	DATE

SCALE	1:20	DRAWING NUMBER	REV
DATE	02.12.14	565V1700SD	0
DRAWN	A.Prime		SIZE
CHECKED	D.Egan		A3

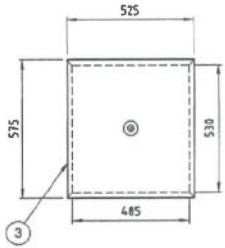

LID PLAN VIEW

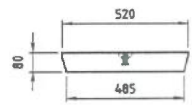

LID FRONT VIEW

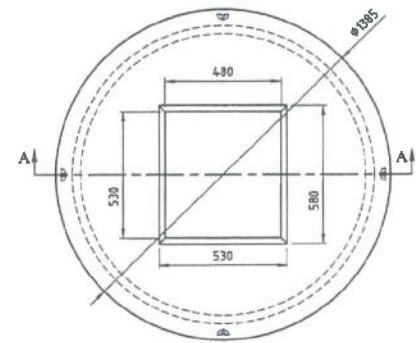

PLAN VIEW

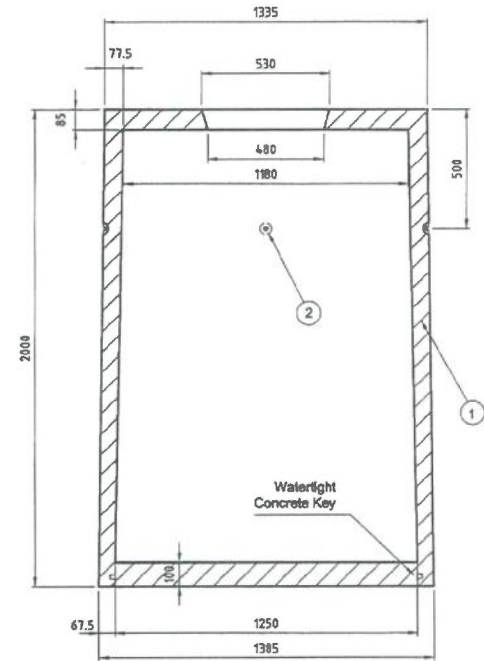

SECTION A-A

APPROVED
 - 8 JAN 2019
 NSW MINISTRY OF HEALTH

CLASS RATING
STANDARD DUTY

LIVE LOAD LIMITS
Maximum 0.51 GVM

DEAD LOAD
0 to 2.0m of Fill

CONCRETE GRADE
40MPa

LIFTING
4 x 1.3t Swivel Anchors (1FA055)

TOTAL MASS
2.000 tonne

NOTES
Reinforcement, refer to Bill of Materials



VIC T: 1300 557 143

TITLE			
2050 L			
SCALE	1:20	DRAWING NUMBER	REV
DATE	02.06.14	2050 L	0
DRAWN	A.Phill		SIZE
CHECKED	D.Egan		A3

NO	ITEM CODE	QTY	DESCRIPTION
1	565V2100SD	1	2,100L Concrete Tank
2	1FA055	4	Foot Anchor - 1.3t x 55mm
3	600V006	1	Square Manhole Cover 575 x 525

NOT FOR DISTRIBUTION		
UNCONTROLLED ONCE PRINTED		
REV	REVISIONS	DATE
0	Product Redrawn	02.06.14

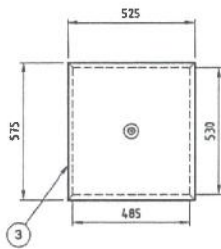

LID PLAN VIEW

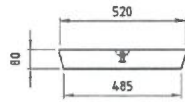

LID FRONT VIEW

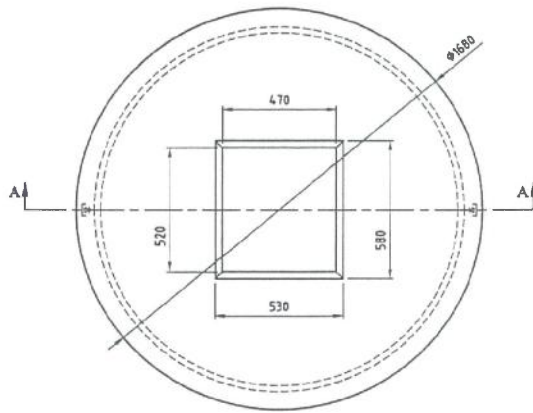

PLAN VIEW

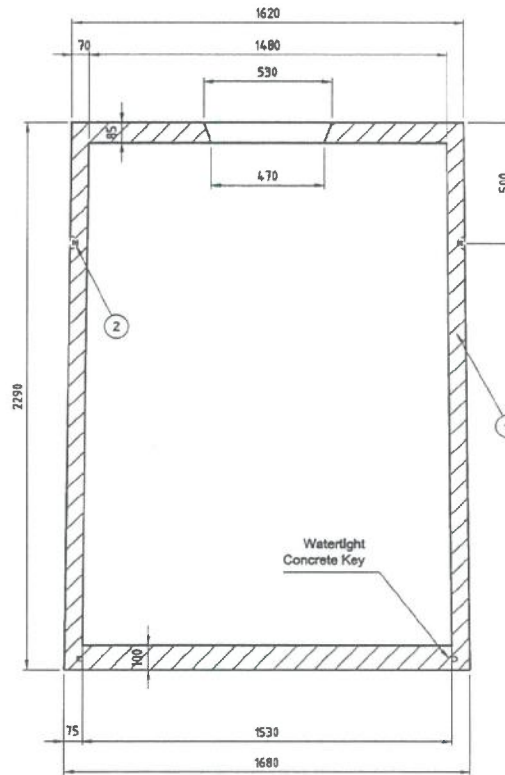

SECTION A-A

SAME
DIMENSIONS
AS 3750L
COLLECTION
WELL

APPROVED
- 8 JAN 2019
NSW MINISTRY OF HEALTH

CLASS RATING
STANDARD DUTY

LIVE LOAD LIMITS
Maximum 0.5t GVM

DEAD LOAD
0 to 2.0m of Fill

CONCRETE GRADE
40MPa

LIFTING
4 x 1.3t Swivel Anchors
(1FA055)

TOTAL MASS
2.610 tonne

NOTES
Reinforcement, refer to
Bill of Materials



VIC T: 1300 557 143

TITLE			
3,800 Litre Concrete Tank Standard Duty			
SCALE	1:20	DRAWING NUMBER	REV
DATE	02.08.14	565V3800SD	0
DRAWN	A.Pritt		SIZE
CHECKED	D.Egan		

NO	ITEM CODE	QTY	DESCRIPTION
1	565V3800SD	1	3,800L Concrete Tank
2	1FA055	4	Foot Anchor - 1.3t x 55mm
3	600V006	1	Square Manhole Cover 575 x 525

NOT FOR DISTRIBUTION		
UNCONTROLLED ONCE PRINTED		
0	Product Redrawn	02.08.14
REV	REVISIONS	DATE

CLASS RATING
STANDARD DUTY

LIVE LOAD LIMITS
Maximum 0.5t GVM

DEAD LOAD
0 to 0.6m of Fill

CONCRETE GRADE
40MPa

LIFTING
4 x 1.3t Swivel Anchors (1FA055)

TOTAL MASS
3.710 tonne

NOTES
Reinforcement, refer to Bill of Materials



APPROVED
- 8 JAN 2019
NSW MINISTRY OF HEALTH

ICON SEPTTECH
VIC

T: 1300 557 143

TITLE
4650L

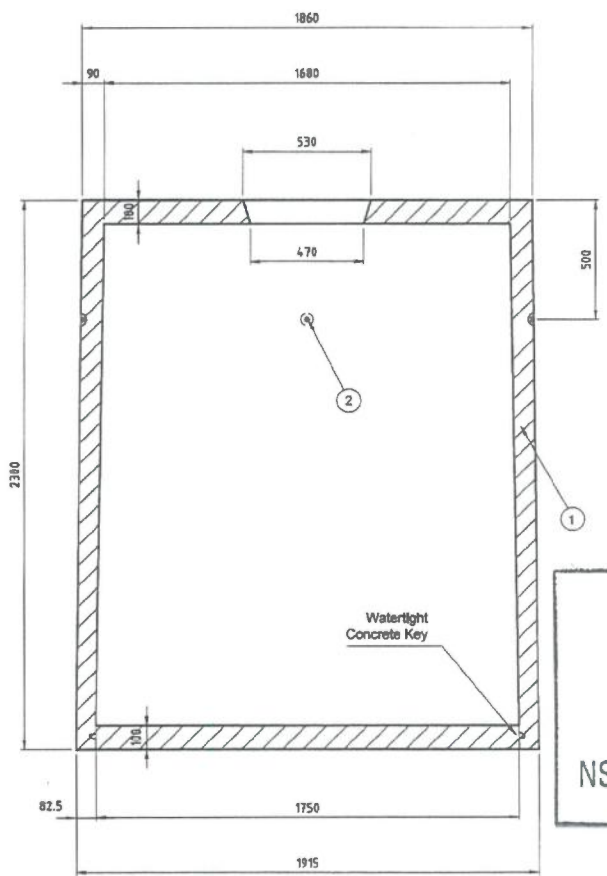

SECTION A-A

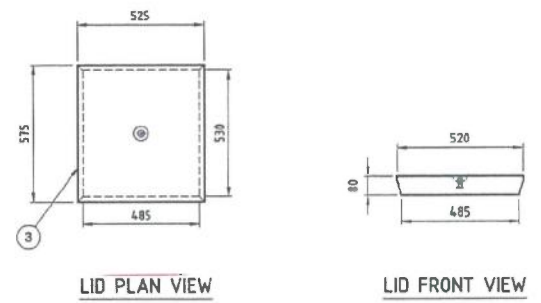

LID PLAN VIEW

LID FRONT VIEW

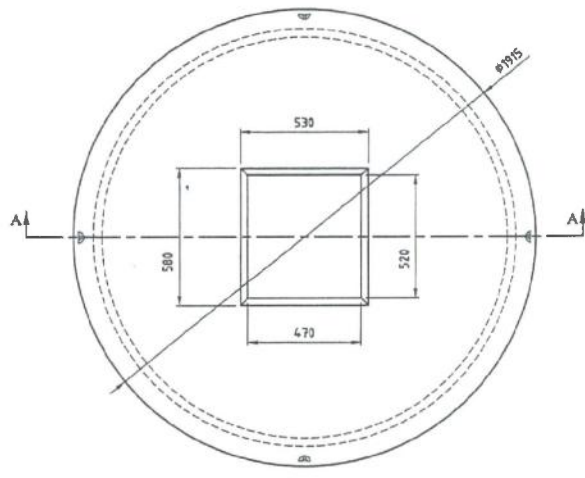

PLAN VIEW

NO	ITEM CODE	QTY	DESCRIPTION
1	565V5000SD	1	5,000L Concrete Tank
2	1FA055	4	Foot Anchor - 1.3t x 55mm
3	600V006	1	Square Manhole Cover 575 x 525

NOT FOR DISTRIBUTION		
UNCONTROLLED ONCE PRINTED		
REV	REVISIONS	DATE
0	Product Redrawn	02.12.14

SCALE	1:20	DRAWING NUMBER	REV
DATE	02.12.14	4650L	0
DRAWN	A.Pittill		SIZE
CHECKED	D.Egan		A3

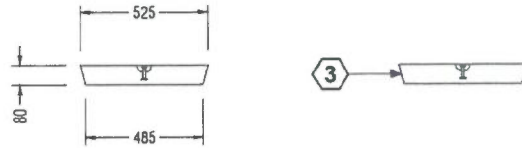

COVER DETAIL

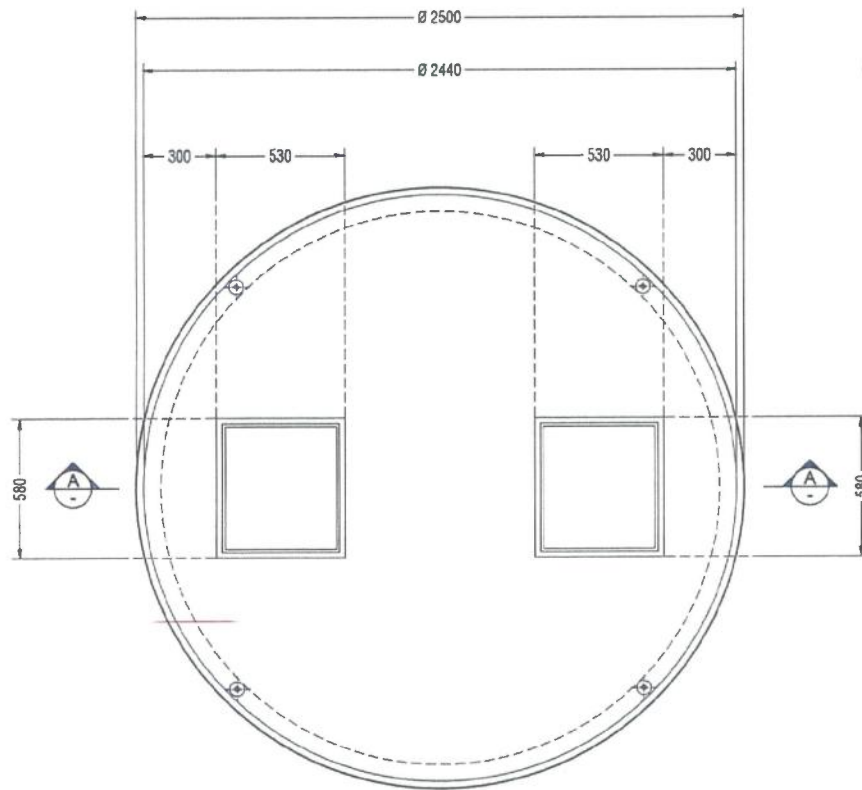

PLAN VIEW

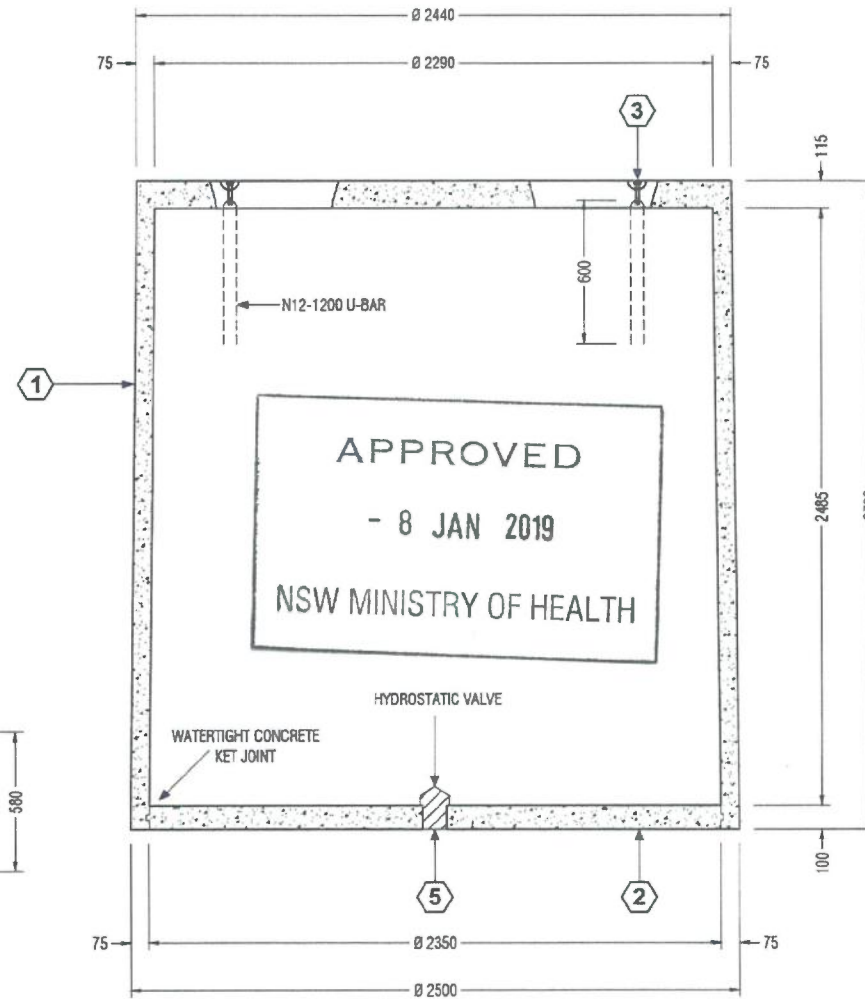

SECTION A-A (TANK)

CLASS RATING :

STANDARD DUTY

LIVE LOAD

MASS LIMITS :

MAXIMUM = 0.5T GVM

DEAD LOAD :

0 TO 1.0 m OF FILL

CONCRETE GRADE :

CONCRETE STRENGTH 40 MPa
EXPOSURE CLASSIFICATION B1
AS 3600-2001

TOTAL MASS :

6.000 TONNES

LIFTING :

4 x 2.5T SWIFTLIFT EYE ANCHORS
(2REA070)

NOTES :

BEARING CAPACITY OF SOIL
UNDER THE TANK TO BE
150KPa MINIMUM



T : 1300 557 143
W : www.mcpipes.com.au

No.	ITEM CODE	QTY	DESCRIPTION
1	565V10500TSD	1	10,500 CONCRETE TANK TOP - SD
2	565V10500BSD	1	10,500 CONCRETE TANK BASE - SD
3	2REA070	4	COMBINATION ANCHOR - 2.5T x 70 mm
4	800V006	2	SQUARE MANHOLE COVER
5	805A110	1	HYDROSTATIC VALVE

No.	DATE	REVISIONS
A	07.10.14	FIRST ISSUE

ICON SEPTech VIC

TITLE
ICON SEPTech
10,500 LITRE CONCRETE TANK
STANDARD DUTY

SCALE	-	DRG No.	565V10500SD	REV	A
DATE	07.10.14	DRAWN	R.P.	CHECKED	D. EGAN
		SIZE	A3		