



Health

# Certificate of Accreditation

## Sewage Management Facility

### Septic Tanks & Collection Wells

*This Certificate of Accreditation is issued by the Secretary of the NSW Ministry of Health pursuant to Clause 41(1) of the Local Government (General) Regulation 2005.*

**Manufacturer:** *Hopley Pty Ltd t/a Sepron*

**Of:** *59 McCombe Road, Bunbury, WA, 6230*

*The polyethylene Sepron Septic Tanks as described in the following Schedule have been accredited as sewage management facilities for use in single domestic premises in NSW.*

*Director, Environmental Health  
for Secretary (delegation PH335)*

**Issued:** *15 January 2019*

**Certificate No:** *STCW042*

**Expires:** *31 December 2024*



Health

## ***Accreditation Schedule***

*The Certificate of Accreditation applies to the following  
Septic Tanks and Collection Wells*

Model	Description	Size
Septic Tank	Vertical axis type cylindrical rotomoulded polyethylene tank, with partitions, lid, access cover. Burial depth is restricted to 0 mm.	2,200 L (1,200 L for composite installation)
Collection Well	Vertical axis type cylindrical rotomoulded polyethylene tank with, lid, and access cover. Burial depth is restricted to 0 mm	2,200 L
Composite Septic Tanks	Vertical axis type cylindrical rotomoulded polyethylene tank with lid, and access cover. Burial depth is restricted to 0 mm Wastewater is to flow from the larger tank to the smaller tank. The tanks are to be located on a common concrete slab to prevent differential movement	3,400 L (2200 L with partition removed and 1200 L second tank)

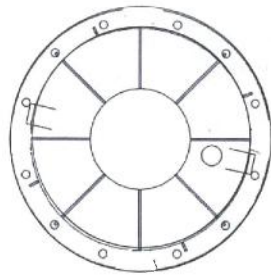

1 1200 LITRE SEPTIC PLAN  
1 : 20



APPROVED  
15 JAN 2019  
NSW MINISTRY OF HEALTH

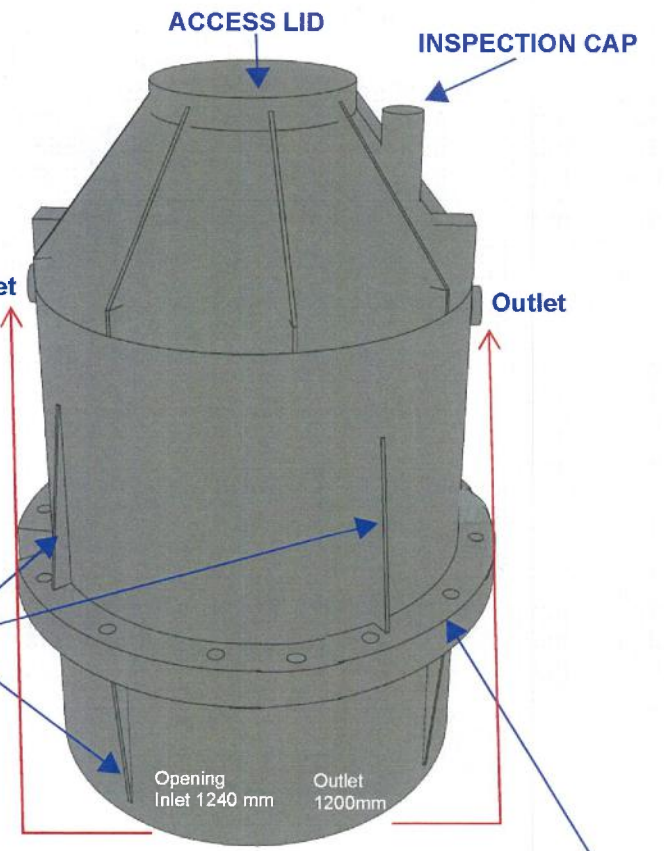

2 3D PERSPECTIVE



Patent Number:  
12956/2008  
  
59 McCombe Road,  
Bunbury WA 6231  
  
ABN: 19 103 247 294



**VEEN'S**  
Design Drafting Service  
*For all your professional drawing requirements*

PHONE: 9721 2526 FAX: 9721 2527  
Email: admin@veensdesigndrafting.com.au  
SUITE 1 - 26 CAREY STREET, BUNBURY, 6230  
www.veensdesigndrafting.com.au

No.	Description	Date

**PLAN & PERSPECTIVE**

Project number	8062-13
Date	15/03/13
Drawn by	MF
Checked by	RV

**A3-A03** Scale As indicated

Name : Sepron 1200lt Plastic Tank  
Model : SEP1200  
Size : 1200lt  
Function - Septic Waste Water Tank

4/04/2013 4:16:01 PM

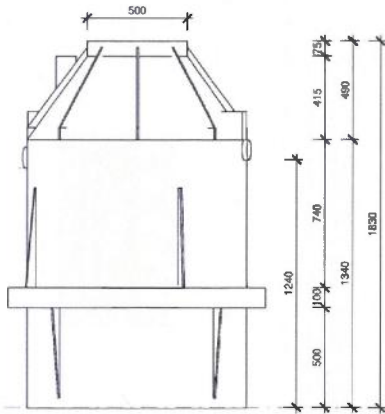

1 ELEVATION 1  
1 : 20

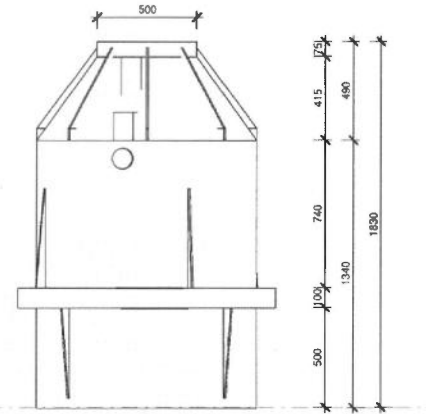

2 ELEVATION 2  
1 : 20

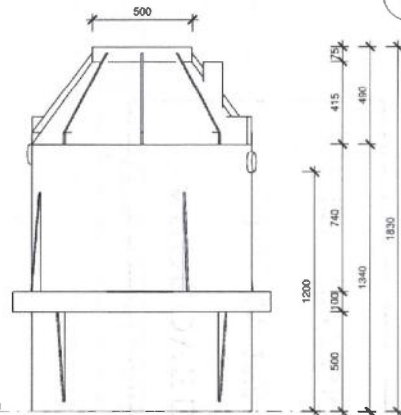

3 ELEVATION 3  
1 : 20

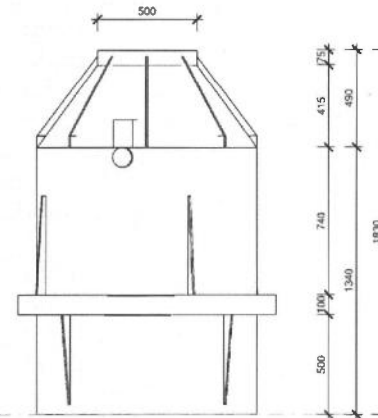

4 ELEVATION 4  
1 : 20



Patent Number:  
12956/2008

59 McCombe Road,  
Bunbury WA 6231

ABN: 19 103 247 294

**VEEN'S**  
Design Drafting Service  
*For all your professional drawing requirements*

PHONE: 9721 2526 FAX: 9721 2527  
Email: [admin@veensdesigndrafting.com.au](mailto:admin@veensdesigndrafting.com.au)  
SUITE 1 - 26 CAREY STREET, BUNBURY, 6230  
[www.veensdesigndrafting.com.au](http://www.veensdesigndrafting.com.au)

No.	Description	Date

1200lt ELEVATIONS	
Project number	8062-13
Date	15/03/13
Drawn by	MF
Checked by	RV
Scale	As Indicated

Name : Sepron 1200lt Plastic Tank  
Model : SEP1200  
Size : 1200lt  
Function - Septic Waste Water Tank

**A3-A04**

**APPROVED**  
**15 JAN 2019**  
**NSW MINISTRY OF HEALTH**

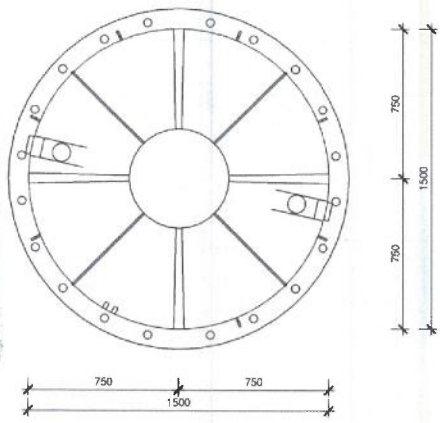

**1** 2200 LITRE SEPTIC PLAN  
 1 : 20



Patent Number:  
 12956/2008  
 59 McCombe Road,  
 Bunbury WA 6231  
 ABN: 19 103 247 294

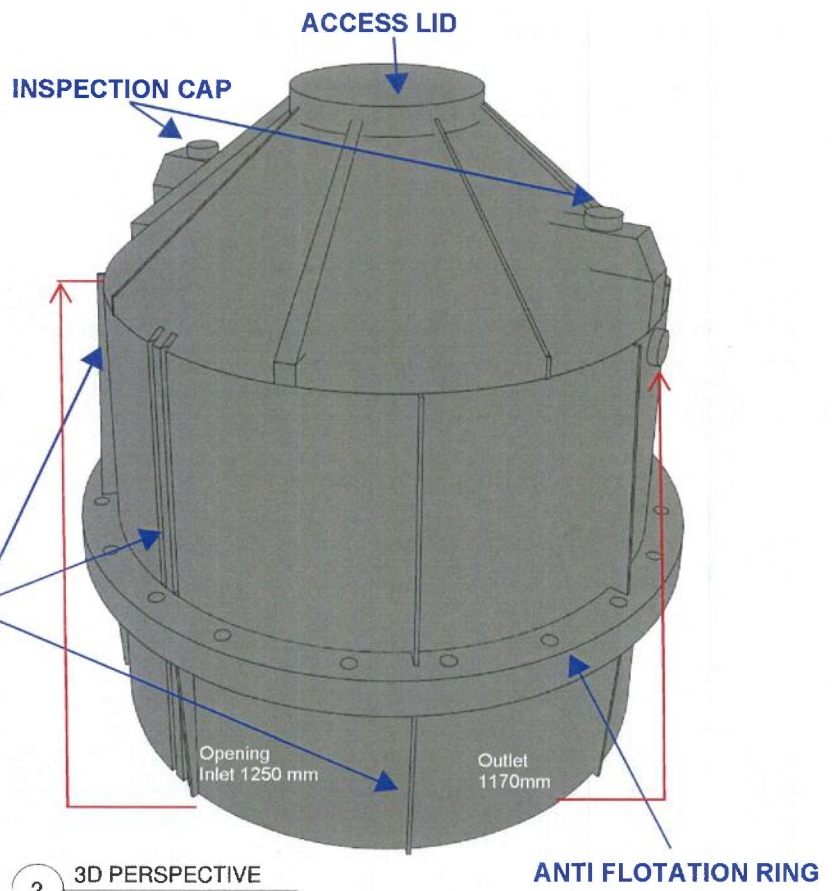

**2** 3D PERSPECTIVE

**VEEN'S**  
**Design Drafting Service**  
 For all your professional drafting requirements  
 PHONE: 9721 2526 FAX: 9721 2527  
 Email: admin@veensdesigndrafting.com.au  
 SUITE 1 - 26 CAREY STREET, BUNBURY, 6230  
 www.veensdesigndrafting.com.au

No.	Description	Date

PLAN & PERSPECTIVE	
Project number	8062-13
Date	15/03/13
Drawn by	MF
Checked by	RV
Scale	As indicated

Name : Sepron 2200lt Plastic Tank  
 Model : SEP2200(No Baffle) SEPBAF2200 (With Baffle)  
 Size : 2200lt  
 Function - Septic Waste Water Tank (Sedimentation Tank) (With/Without Baffle)

4-04-2013 4:17:27 PM

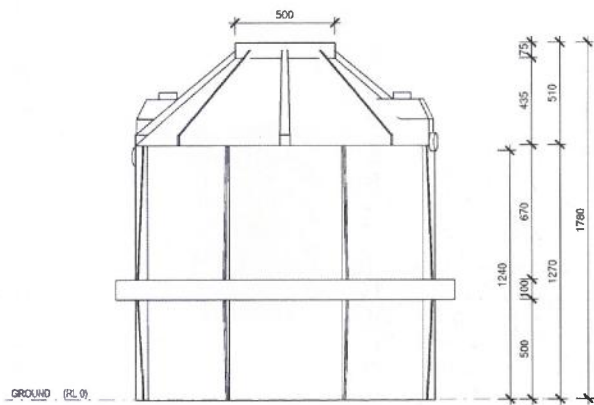

1 ELEVATION 1  
1 : 20

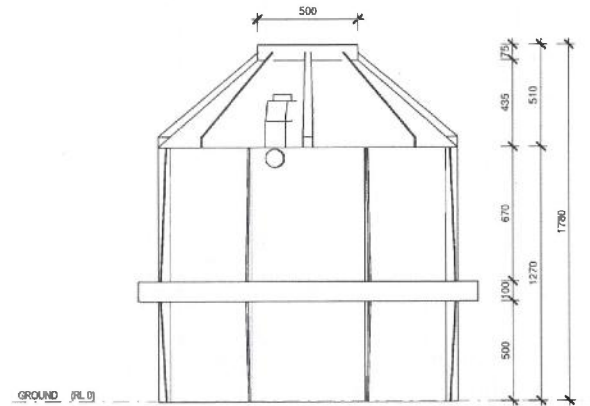

2 ELEVATION 2  
1 : 20



Patent Number:  
12956/2008

59 McCombe Road,  
Bunbury WA 6231

ABN: 19 103 247 294

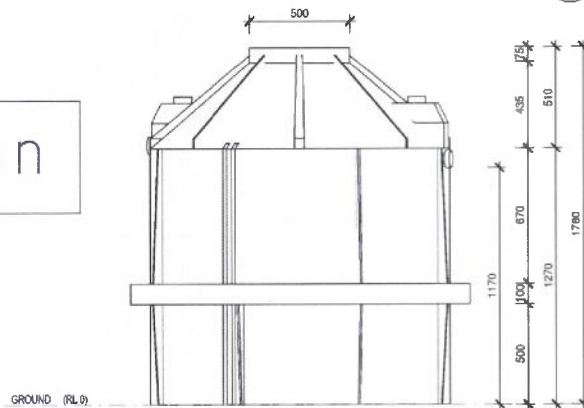

3 ELEVATION 3  
1 : 20

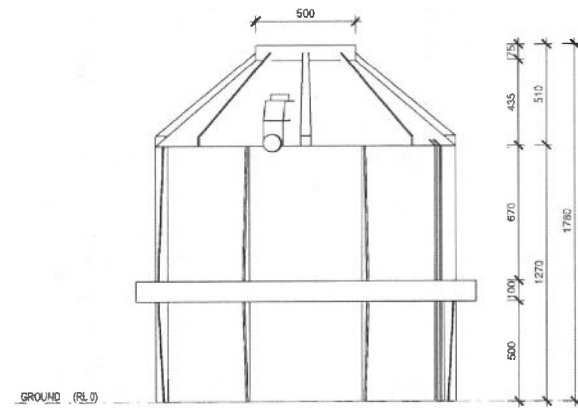

4 ELEVATION 4  
1 : 20

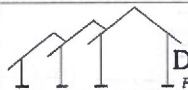

PHONE: 9721 2526 FAX: 9721 2527  
Email: admin@veen'sdesigndrafting.com.au  
SUITE 1 - 28 CAREY STREET, BUNBURY, 6230  
www.veen'sdesigndrafting.com.au

VEEN'S  
Design Drafting Service

For all your professional drawing requirements



No.	Description	Date

2200lt ELEVATIONS

Project number	9062-13
Date	15/03/13
Drawn by	MF
Checked by	RV
Scale	As indicated

A3-A02

Name : Sepron 2200lt Plastic Tank  
Model : SEP2500  
Size : 2200lt  
Function - Septic Waste Water Tank (Sedimentation Tank) (With/Without Baffle)

4/04/2013 4:17:04 PM